

Design No. FC 200

FLOOR / CEILINGS

Assembly Rating: 1-1/2 hr

ASTM E 119-00a

CAN / ULC / S101

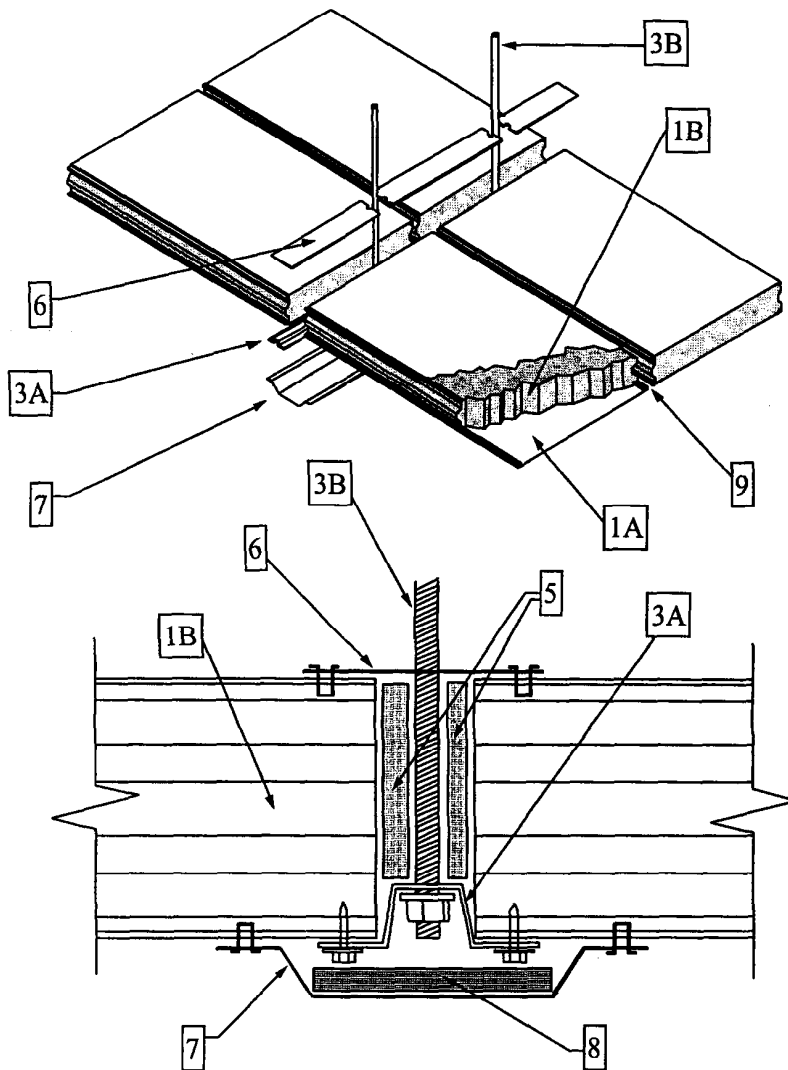

1. **INSULATED CEILING PANELS:** Steel or stainless steel faced panels, with a core of mineral wool insulation. The panels are nominally 42 inches wide, having a maximum length of 12 feet and have a minimum thickness of 6 inches. The panels are constructed with a tongue and groove interface

connection on the long dimension edges, that which mate with adjacent panels. When constructing a ceiling, the panels are supported by a Hanger-Tee support system as described in Item 3. The panel perimeter is secured with panel attachment angles or channel, as

## Fire-Resistant Floor/Ceilings

described in Item 4. The panels are constructed of the following materials:

- A. Panel Facing – The panel facing is constructed of minimum 26 GA galvanized steel with painted or mill finish, or minimum 26 GA stainless steel with mill finish. The panels are constructed with the tongue and groove edge configuration located on the long dimension panel edges.
- B. Mineral Wool Insulation – The panel core consists of nominal 8.5 pcf density mineral wool board that is sandwiched between and adhered to the panel facing with a polyurethane adhesive. The long dimension edges of the panel core are cut to a tongue and groove connection interface that mate adjoining panels.

### Listed Manufacturer:

Metl-Span I, Ltd.  
Ceiling Panels

### **THERMSAFE®**

#### Mineral Fiber Insulated Panels

2. SILICONE SEALANT: [NOT SHOWN] Apply a nominal 3/16 inch bead of one-component, medium modulus, non-corrosive silicone sealant to the inside of the tongue-and-groove panel joints prior to mating adjoining panels on the top-side of the assembly (also referred to as the “cold-side”—the side that is not exposed to direct flames). [Note — Applying a nominal 3/16 inch bead of one-component, medium modulus, non-corrosive silicone sealant to the inside of the tongue-and-groove panel joints prior to mating adjoining panels on the bottom-side (also referred to as the fire-side) is optional, and not required for fire resistance.]
3. CEILING PANEL SUPPORTS: Secure the panel supports to the adjacent construction as required by code. The following method of panel support is recognized in this listing:
  - A. “Hanger-Tee” Support System – Minimum 12 GA galvanized steel “hat”-shaped channel, having minimum flange lengths of 1-5/8 inches. Install channels at a maximum spacing of 12 feet on-center. Secure panels to steel channel with minimum No. 12, self-drilling or self-tapping steel screws having sufficient length to extend through the steel

channel support flange and fully engage the panel face. Space the screws 3 inches either side of the panel joint and maximum 12 inches on-center between.

- B. Use a minimum 1/2 inch diameter continuous threaded steel rod to secure the steel support channel to overhead building support as required by building code. Install rods a maximum spacing of 5 feet on-center. Maximum 1/2 inch thread projection of the steel rod through bottom of steel support channel. [Note — insulating the continuous-thread steel rods with a fiberglass sleeve above the Hanger-Tee support system is optional, and not required for fire resistance.]
4. PERIMETER PANEL SUPPORTS: [NOT SHOWN] Secure the panel supports to the adjacent construction as required by building code. The following methods of panel attachment along the perimeter is recognized in this listing:
    - A. Supports – Minimum 16 GA steel sheeting angles having minimum 2-inch flanges, or equivalent structural member providing equal or greater support. Secure panels to supports with minimum No. 12, self-drilling or self-tapping steel screws with sufficient length to extend through the support flange and fully engage the panel face. Space the screws 3 inches either side of the panel joint and maximum 12 inches on-center between.
    - B. Intermediate Supports – [Optional, not required for fire resistance] Where panel ceilings require additional support for project specific reasons: intermediate steel supports may be installed in accordance with the manufacturer’s instructions, on the panel span between the Hanger-Tee supports, using No. 14 self-drilling or self-tapping screws having sufficient length to extend through the panel and completely into the steel support on the opposite side. Spacing is determined by project requirements.
  5. CAVITY INSULATION: Unfaced mineral fiber board insulation having a nominal 4.0 pcf density. Cut mineral fiber board 1-1/2 times the width of the Hanger-Tee joint and compress to fit inside. Install sufficient layers of mineral fiber board insulation to fill the cavity space.

*Fire-Resistant Floor/Ceilings*

6. **TOP JOINT COVER:** Minimum 26 GA galvanized steel with painted or mill finish, or minimum 26 GA stainless steel with mill finish. Install a nominal 3/16 inch bead of one-component, medium modulus, non-corrosive silicone sealant under each edge of the Top Joint Cover. Any of the following methods of attaching the Top Joint Cover to the ceiling panels is recognized in this Listing:  
a) Minimum No. 12, self-drilling or self-tapping steel screws having sufficient length to extend through the Top Joint Cover and fully engage the panel face. Space screws a maximum of 12 inches on-center. b) 1/8 inch stainless steel pop rivets having sufficient length to extend through the Top Joint Cover and fully engage the panel face. Space rivets a maximum of 12 inches on-center.
7. **BOTTOM JOINT COVER:** Minimum 26 GA galvanized steel with painted or mill finish, or minimum 26 GA stainless steel with mill finish. [*Note — The use of Butyl sealant tape applied on each flange of the Bottom Joint Cover is optional and not required for fire resistance*]. Any of the following methods of attaching the Bottom Joint Cover to the ceiling panels is recognized in this Listing:  
a) Minimum No. 12, self-drilling or self-tapping steel screws having sufficient length to extend through the Bottom Joint Cover and fully engage the panel face. Space screws a maximum of 12 inches on-center. b) 1/8 inch stainless steel pop rivets having sufficient length to extend through the Bottom Joint Cover and fully engage the panel face. Space rivets a maximum of 12 inches on-center.
8. **JOINT CAVITY INSULATION:** Install sufficient layers of ceramic fiber insulation (having a nominal 6.0 pcf density and total nominal, non-compressed thickness of 1-1/2 inches) to fill the cavity space located between the Bottom Joint Cover and beneath the Hanger-Tee support system.
9. **CEILING PANEL ATTACHMENT:** [*NOT SHOWN*] On the bottom-side of the ceiling assembly (also referred to as the “fire-side”—the side that is exposed to direct flames): Install 1/8 inch stainless steel pop rivets to secure all ceiling panel tongue-and-groove joints as described in Item 1A. Space rivets a maximum of 36 inches on-center.