

Design No. NBW 344
NON-BEARING WALL
Assembly Rating – 1 hr
ASTM E-119

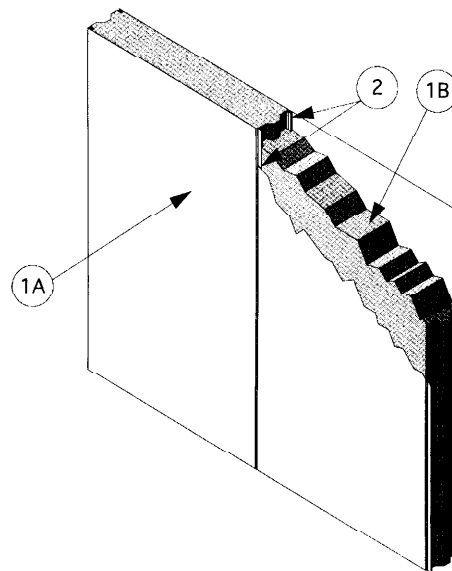

1. INSULATED WALL PANELS: Steel or stainless steel faced panels, with a core of mineral wool insulation. The panels are nominally 42 in. wide, having a maximum length of 50 feet and a minimum thickness of 4 in. The panels are constructed with tongue and groove interfaces on the long dimension edges, that mate with adjacent panels. Panels may be installed with the long dimensions placed horizontally or vertically. When constructing a wall, the panel perimeter is secured with panel attachment angles or channel, as described in Item 3. The wall panels are constructed of the following materials:

A. Panel Facing – The panel facing is constructed of min. 26 GA galvanized steel with painted or mill finish, or min 26 GA stainless steel with mill finish. The panels

are fashioned with tongue and groove mating edges located on the long dimension panel edges.

B. Mineral Wool Insulation – The panel core consists of nominal 8.5 pcf mineral wool batt that is sandwiched between the panel facing and adhered to the panel facing with a polyurethane adhesive. The long dimension edges of the panel core are constructed with a tongue and groove interface that mates with adjoining panels.

Listed Manufacturer:

Metl-Span I, Ltd.

Roofing and Siding Panels

Metal Roof and Wall Panels

Thermalsafe® Panels

Fire-Resistant Walls

2. Silicone Sealant: (Optional - not required for fire resistance) Install a nominal 3/16 in. bead of one-component, medium modulus, non-corrosive silicone sealant to the female side of the panel facing (1A) joints prior to joining the panels.
3. Panel Supports: (not shown) – Panels are attached to side perimeter panel supports when installed horizontally, or top and bottom panel supports when installed vertically. Secure the panel supports to the adjacent construction as required by code. Any of the following methods of panel attachment is recognized in this Listing:
 - A. Channel: Minimum 18 GA galvanized steel C-shaped channel, or track, having a web width 1/8 in. larger than the wall thickness and minimum flange length of 2 in. Secure panels to double supports with min. No. 12, self drilling or self tapping steel screws having sufficient length to extend through the support flange and fully engage the panel face. Space the screws max. 12 in. OC.
 - B. Single Supports: Min. 16 GA. steel sheeting angles having minimum 2 in. flanges, or equivalent structural member providing equal or greater support. Secure panels to single supports with min. No. 14, self drilling or self tapping steel screws with sufficient length to extend through the panel, and completely into the steel support on the opposite side. Space the screws max. 18 in. OC and 3 in. from each joint.
 - C. Double Supports: Min. 16 GA. steel sheeting angles having minimum 2 in. flanges, or equivalent structural member providing equal or greater support. Secure panels to double supports with min. No. 12, self drilling or self tapping steel screws having sufficient length to extend through the support flange and fully engage the panel face. Space the screws max. 12 in. OC.
 - D. Intermediate Supports: (Optional, not required for fire resistance) Where panel walls require additional support for project specific reasons, intermediate steel supports may be installed, in accordance with manufacturer's instructions, on the panel span between the end panel support connections, using #14 self-drilling or self-tapping screws having sufficient length to extend through the panel, and completely into the steel support on the opposite side, or #10 FabLok rivets. Spacing is determined by project requirements.